

AARON MANUFACTURING INC.

EXHAUST VENT SYSTEMS FOR DISHWASHERS

DATE: 8-17-04

STANDARD FEATURES

SPECIFICATION: Exhaust vents are 18 gauge stainless steel all welded construction. All seams and joints are sealed watertight with silicone or approved sealant. All fabrication per N.S.F. #2 standards. Contact Aaron Bid Department for specific pricing for modified units and accessories. Note: Verify jobsite conditions and co-ordinate fabrication with exhaust vent contractor or with jobsite contractor.

JOB NAME : _____
 LOCATION : _____
 ITEM # _____
 MODEL # _____
 QUANTITY : _____

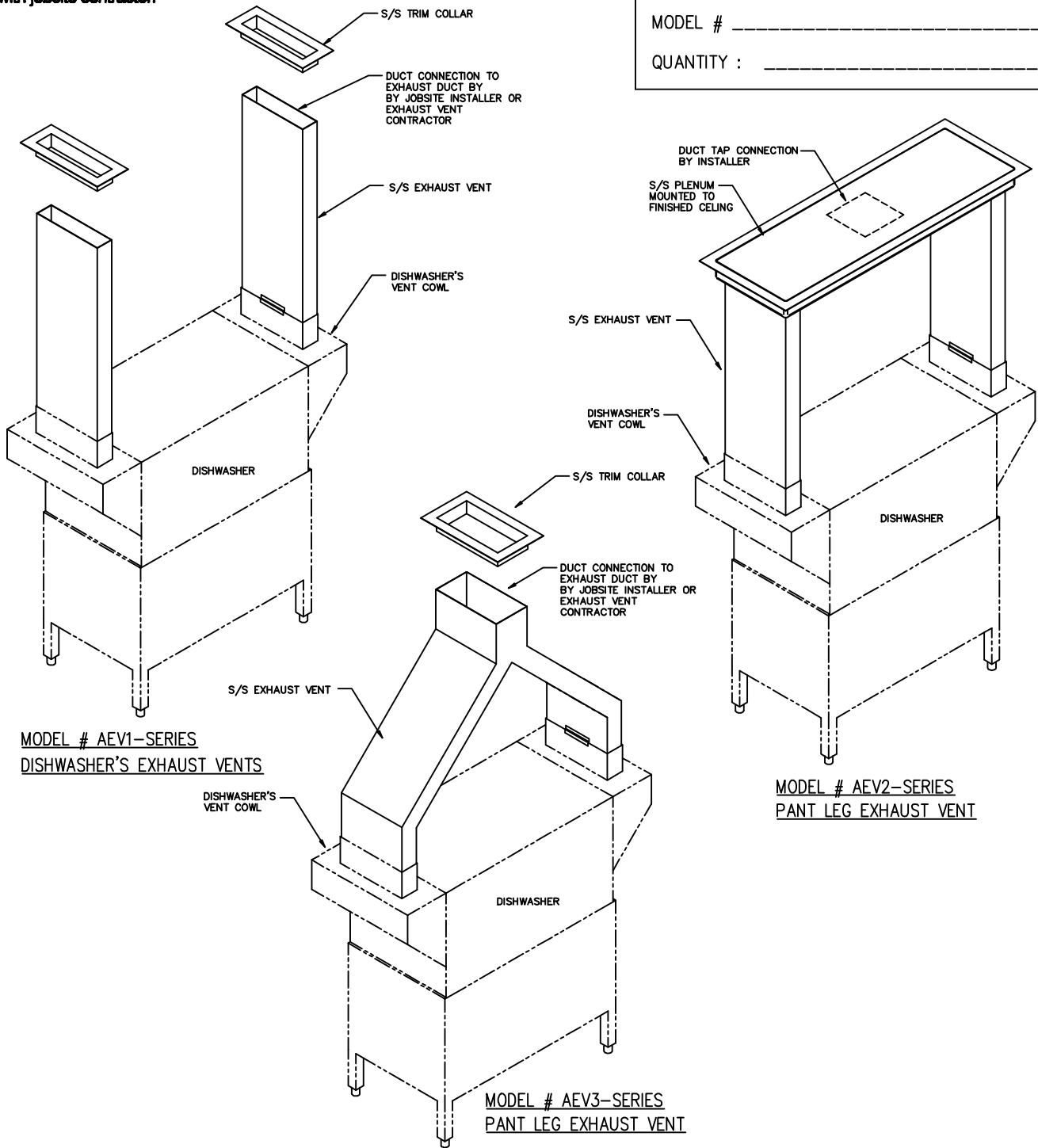

AARON MANUFACTURING INC.